

**SECTION B-B
TYPE 1 GENERAL USE**

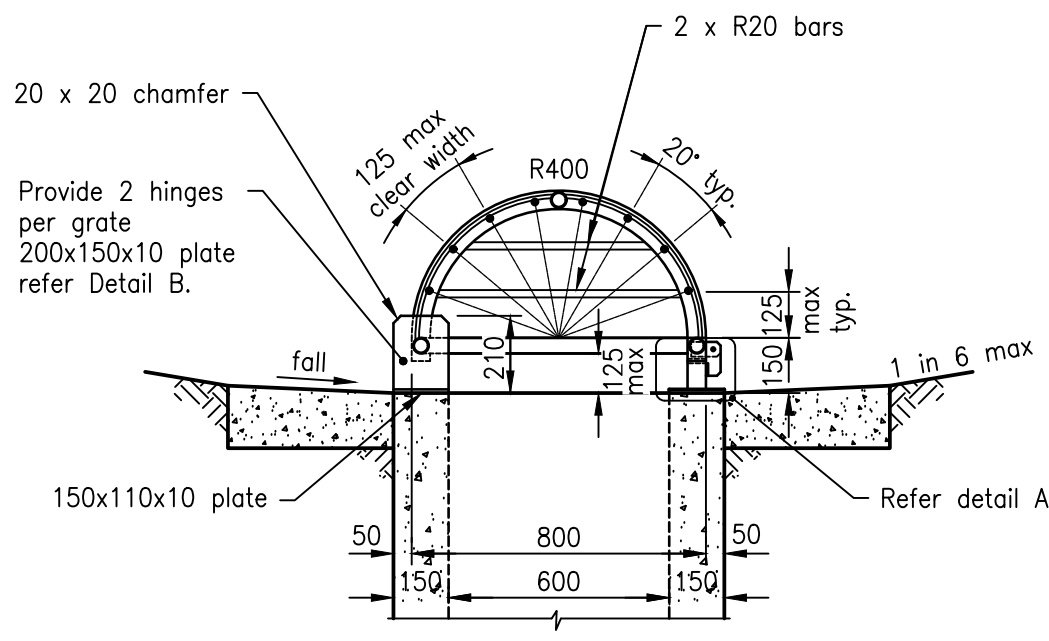

SECTION A-A

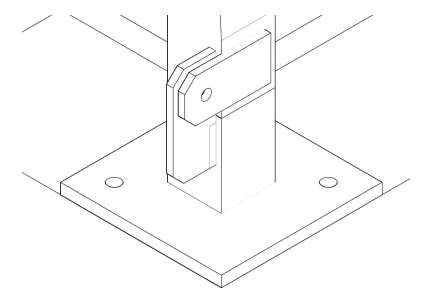

LOCKING UNIT A

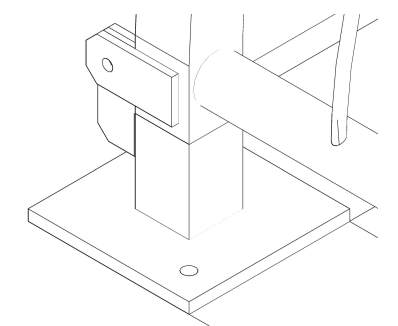

LOCKING UNIT B

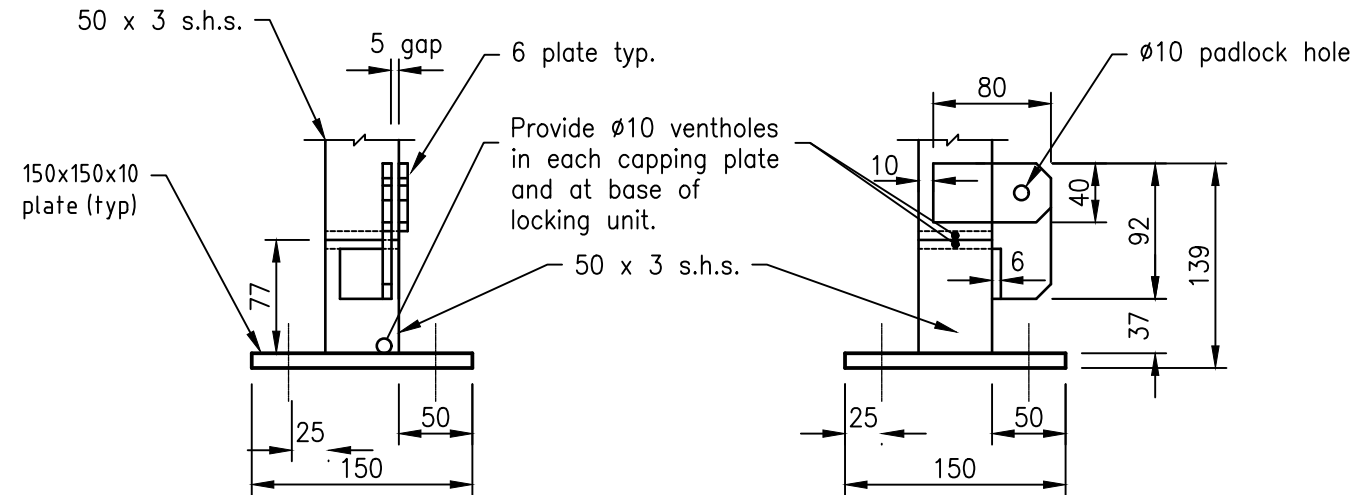

DETAIL A

DETAIL B

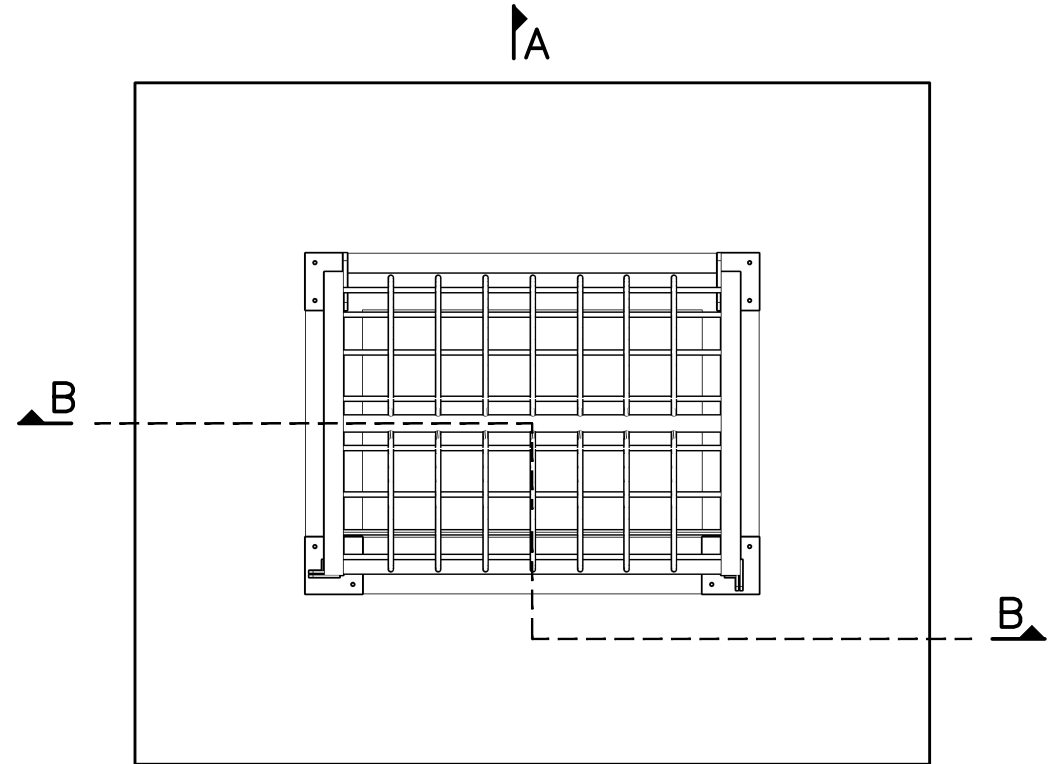

PLAN

NOTES:

1. Concrete to be grade N32.
2. All components to be hot-dipped galvanised to AS/NZS 4680 after fabrication.
3. All welds 6mm c.f.w. all round.
4. All edge distances to chemical anchors to be not less than 25mm.
5. Locking units to be secured with hot dipped galvanised m8 bolts with snug tightened nut upon installation.
6. Ensure clear opening widths of 125 max in fabrication and installation for child proof safety.
7. Dimensions are in millimetres unless shown otherwise.

THIS IS NOT A FRANGIBLE ITEM

These drawings have been developed in consultation between the participating Councils.
BEFORE USE, the user shall confirm that the drawing has been adopted by the appropriate Council.

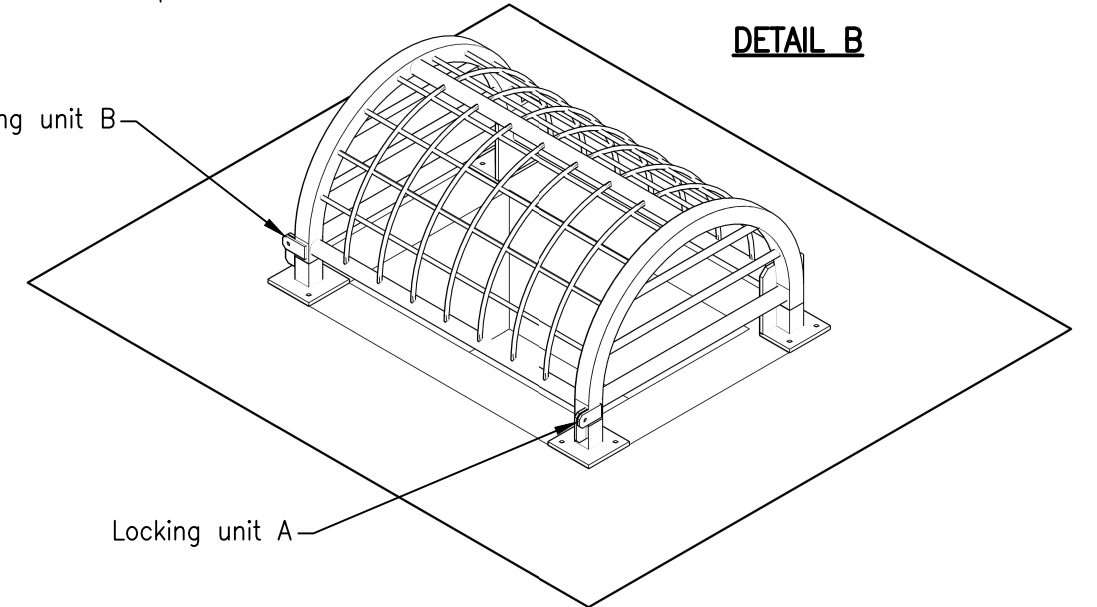

ISOMETRIC VIEW

Rv.	DATE	REVISIONS
B	06/14	Review
A	10/13	ORIGINAL ISSUE



**INSTITUTE OF PUBLIC WORKS ENGINEERING AUSTRALASIA
STANDARD DRAWINGS**

**DRAINAGE PITS
FIELD INLET PIT
DOME TOP COVER (900x600)**

DS-069

B	A	Rv.